

# Ruby MC Recessed

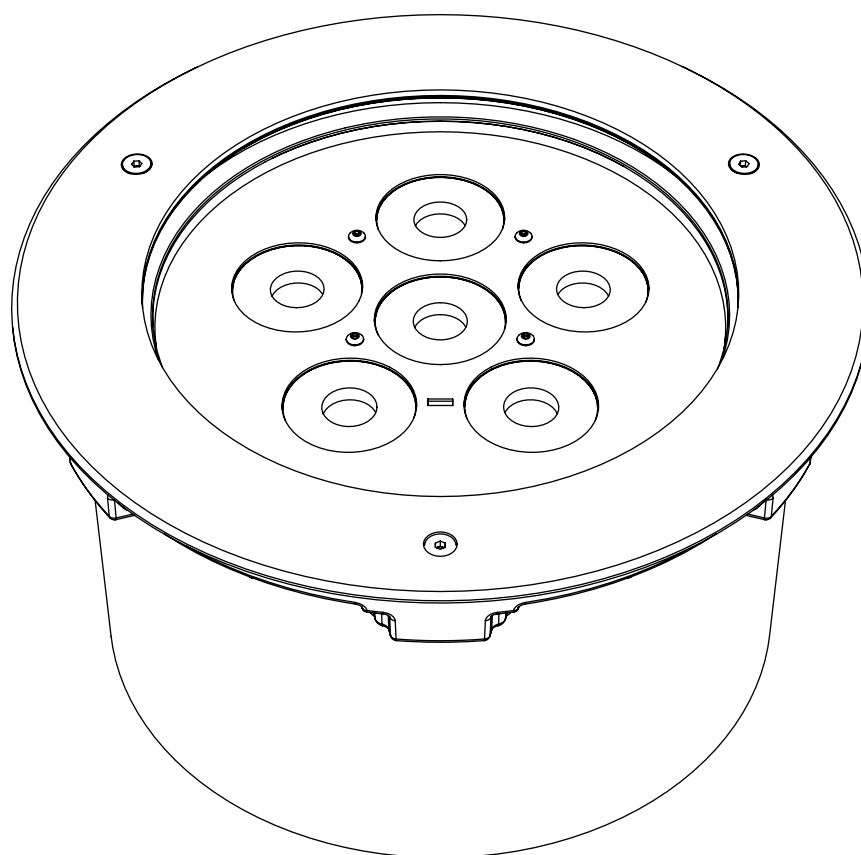

Manuale di istruzioni  
Instructions manual

 **GRIVEN**  
world lighting challenge

# INDEX

<b>1.0 Introduction</b> .....	<b>16</b>
<b>1.1 Safety information</b> .....	<b>16</b>
1.1.1 Protecting against electric shock .....	16
1.1.2 Installation .....	16
1.1.3 Protection against burns and fire .....	16
1.1.4 Weather protection .....	16
1.2 Compliance .....	16
<b>2.0 Size</b> .....	<b>17</b>
<b>3.0 Packaging and transport</b> .....	<b>17</b>
3.1 Packaging .....	17
3.2 Transport .....	17
<b>4.0 Installation</b> .....	<b>18</b>
4.1 Build in specifications .....	18
4.2 Connection to mains power .....	19
4.3 Connection to DMX signal .....	19
<b>5.0 Use of the unit</b> .....	<b>20</b>
5.1 Setting operating mode .....	20
5.2 Setting DMX Address .....	20
5.3 DMX address setting with the accessory Weezerd 1 .....	20
5.4 Setting DMX mode with the accessory Weezerd 1 .....	20
5.5 DMX functions RGBW .....	21
5.5.1 DMX functions with DMX MODE = 4 channels .....	21
5.5.2 DMX functions with DMX MODE = 5 channels .....	21
5.5.3 DMX functions with DMX MODE = 6 channels .....	21
5.6 DMX functions Dynamic white .....	22
5.6.1 DMX functions with DMX MODE = 2 channels .....	22
5.6.2 DMX functions with DMX MODE = 3 channels .....	22
5.7 DMX functions monochromatic .....	22
<b>6.0 Master-Slave and Automatic function</b> .....	<b>23</b>
6.1 MASTER configuration .....	23
6.2 SLAVE configuration .....	24
<b>7.0 Fixed colours mode</b> .....	<b>24</b>
7.1 Fixed colours mode RGBW .....	24
7.2 Fixed colour mode Dynamic white .....	24
7.3 SLAVE configuration RGBW .....	24
7.4 SLAVE configuration Dynamic white .....	24
<b>8.0 Thermal protection</b> .....	<b>24</b>
<b>9.0 No frost glass</b> .....	<b>25</b>
<b>10.0 RDM functions</b> .....	<b>25</b>
<b>11.0 Maintenance</b> .....	<b>25</b>
11.1 Cleaning the unit .....	25
11.2 Regular checks .....	25
<b>12.0 Spare parts</b> .....	<b>26</b>
<b>13.0 Troubleshooting</b> .....	<b>26</b>
<b>14.0 Disposal</b> .....	<b>26</b>
<b>15.0 Technical specifications</b> .....	<b>27</b>

# 1.0 Introduction

## 1.1 Safety information

### Warning!

**This unit is suitable for professional use only, not for domestic use.**

#### 1.1.1 Protecting against electric shock

- Disconnect the unit from mains supply before servicing it or performing any other action.
- Always ground/earth the unit electrically.
- Before connecting the unit to power supplies, verify that operating voltage and frequency are compatible.
- Do not handle the unit with wet hands or in the presence of water.
- Check regularly that the power supply cable is not damaged or crushed.
- Apply to a qualified technician for any regular maintenance action not described in this manual.

#### 1.1.2 Installation

- The unit installation actions must be performed by a qualified staff.

#### 1.1.3 Protection against burns and fire



- Suitable to be installed onto normally inflammable surfaces.
- The unit is not to be installed in places where the ambient temperature exceeds 50° (122°F).

#### 1.1.4 Weather protection

The unit is classified as device with an IP67 weather protection rate.

## 1.2 Compliance



- Product in compliance with EN60598-1.
- Product in compliance with 2002/95/CE (RoHS).

## 2.0 Size

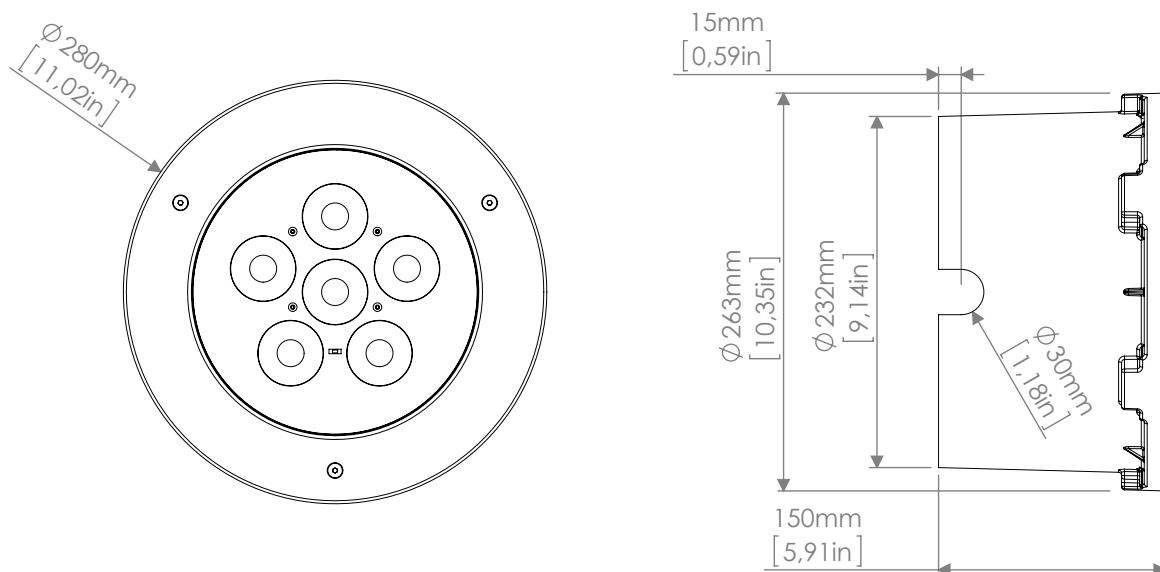

## 3.0 Packaging and transport

### 3.1 Packaging

Check carefully the content of the box and, in case of damage, contact your forwarder immediately. The following items are included in the box of this unit:

- n° 1 **Ruby MC recessed** unit
- n° 1 owner's manual
- n° 2 connection kit

### Warning!

- **Griven S.r.l. liability will cease upon consignment of goods to the forwarder: claims for damage due to transport must be addressed directly to the forwarder.**
- **Griven S.r.l. will accept claims for broken or missing goods only within seven days of receipt of the goods.**
- **Returns of equipment will not be accepted without prior authorization granted by Griven S.r.l. and if not duly accompanied by relevant shipping documents.**

### 3.2 Transport

It is recommended to transport the unit with the maximum care, by using its original packing, to avoid to damage the unit.

## 4.0 Installation

### 4.1 Build in specifications

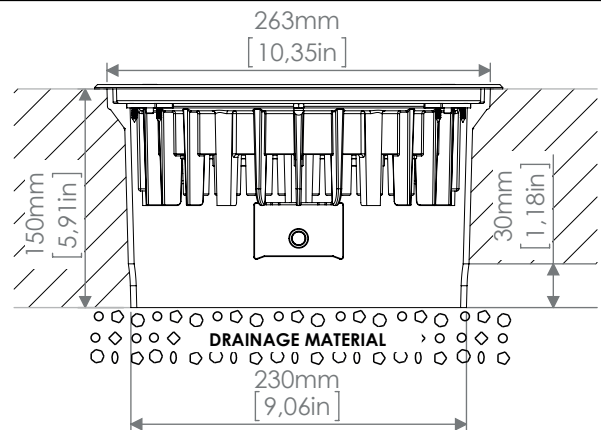
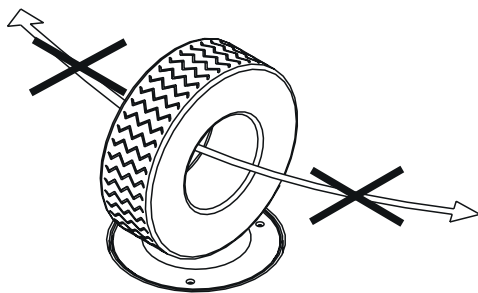
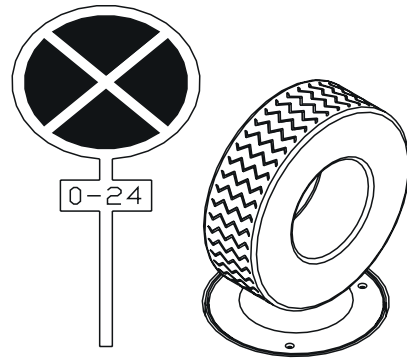
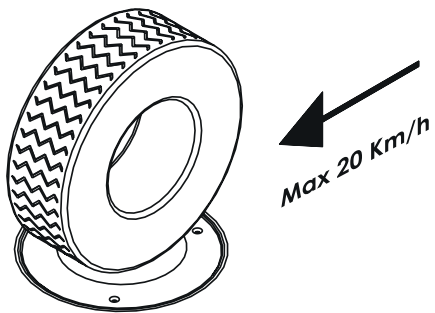
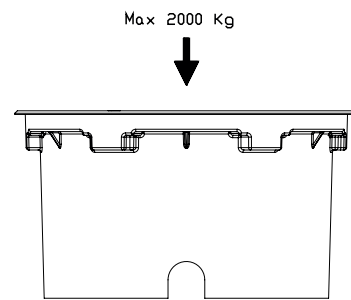
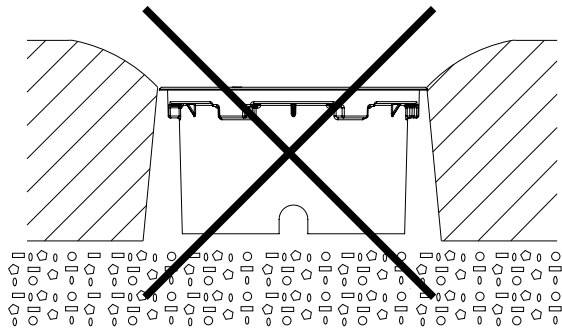

## 4.2 Connection to mains power

The unit can operate with voltage from 100 to 277Vac and with frequency of 50 and 60Hz.

### Warning!

- Before connecting the unit, verify that power supplies features are compatible with the unit features.
- The unit must never be installed if not grounded electrically.
- It is suggested to use a magnetothermic switch along the power supply line, as prescribed by in force rules.
- The unit must not be powered up through a dimmer power device.
- Wiring and connection actions are to be performed by a qualified staff.

For the connection use main cable in the side of the rear boxl of the fixture and connect as shown below.

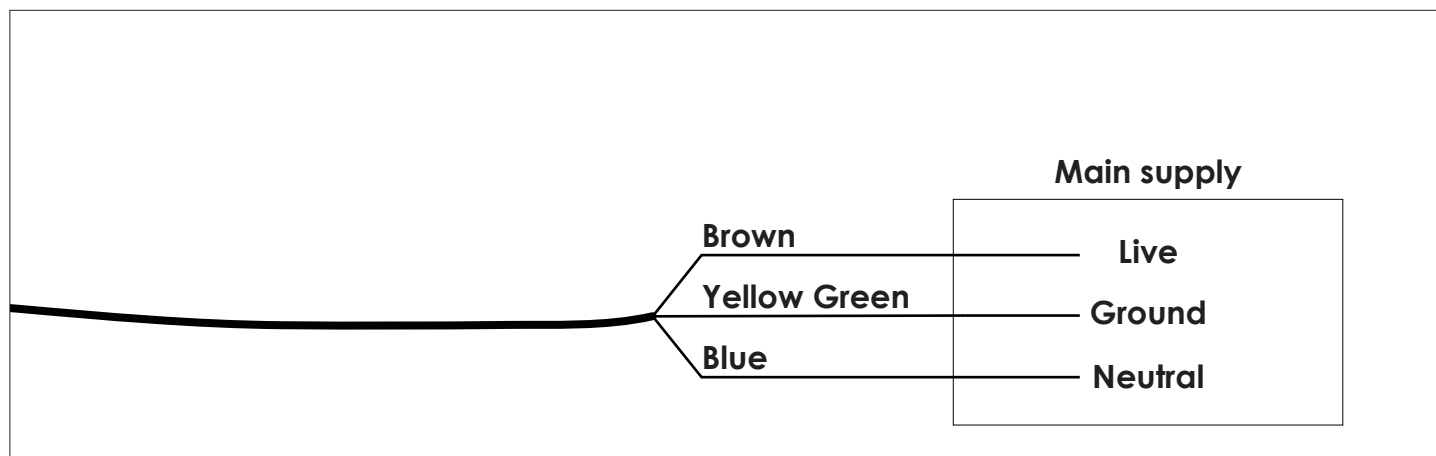

### Warning!

Follow the instructions provided along with the connection kit to perform the connections.

## 4.3 Connection to DMX signal

The DMX signal is to be connected by using a shielded cable designed for devices RS-485.

The signal cable must be connected according to the following table:

GND = Shield  
DATA - = Black  
DATA + = Red

### Warning!

All data wires must be isolated one from another and from the shield.  
The GND of the DMX signal is not to be connected to the electric ground of the unit.  
Insert a terminal plug with a 120  $\Omega$  resistor connected to DATA- and DATA+ in the last unit.

The projector is fitted with butt connectors and heat shrink tube which allow to perform **IP67** connections. To make the connection follow these instructions.

### Warning!

Follow the instructions provided along with the connection kit to perform the connections.

## 5.0 Use of the unit

### 5.1 Setting operating mode

By using the infrared remote control AL1321 it is possible to select one of the following operating mode.

- **using DMX512 signal control mode**

Each fixture is controlled from DMX512 signal control.

- **MASTER-SLAVE or AUTOMATIC mode**

The projector operates independently, without DMX512 signal control. (see chapter 8)

Every button push is confirmed by a very short flash coming from the projector.

The following buttons will be used:



#### Warning!

Before performing any setting operation it is necessary to log in as reported in the chart below.

Function	Buttons	Description
LOGIN		It is the first procedure to be performed. After pushing the buttons 1, 2, 3 it is possible to access the functions settings. The function is confirmed by 1 white flash coming from the projector.
LOGOUT	/	The logout is automatic after 5 minutes of missing reception of the signal coming from the remote control. Once the projector logs out it is not possible to perform any other operation before a new login.

### 5.2 Setting DMX Address

By using the remote control (AL1321) it is possible to select the DMX address and mode:

Funzione	Tasti	Descrizione
Change of DMX mode	+ 1 /.../ 6	Select the number of DMX channels. If the setting is correct then the projector will confirm the procedure by performing 2 white flashes. (e.g. Projector RGBW 5 channels, press 5)
Change of DMX address	+ 0...9	The new entered address must feature 3 digits (e.g. 0 6 7). If the address is correct then the projector will confirm the procedure by performing 3 white flashes

### 5.3 DMX address setting with the accessory Weezerd 1

The DMX address can be set by using the accessory **AL2660 Weezerd 1**. Refer to the manual of the accessory (**Chapter 3.4.1 RDM Dev.**).

### 5.4 Setting DMX mode with the accessory Weezerd 1

The DMX mode can be set by using the accessory **AL2660 Weezerd 1**. Refer to the manual of the accessory (**Chapter 3.4.1 RDM Dev.**).

DMX MODE	CHANNELS USED (RGBW)	CHANNELS USED (Dynamic white)
00	4	2
01	5	3
02	6	/

## 5.5 DMX functions RGBW

### 5.5.1 DMX functions with DMX MODE = 4 channels

Channel	Function	Value	Description
1	Red	0-255	Proportional control 0-100% of the Red color
2	Green	0-255	Proportional control 0-100% of the Green color
3	Blue	0-255	Proportional control 0-100% of the Blue color
4	White	0-255	Proportional control 0-100% of the White color

### 5.5.2 DMX functions with DMX MODE = 5 channels

Channel	Function	Value	Description
1	Red	0-255	Proportional control 0-100% of the Red color
2	Green	0-255	Proportional control 0-100% of the Green color
3	Blue	0-255	Proportional control 0-100% of the Blue color
4	White	0-255	Proportional control 0-100% of the White color
5	Dimmer Strobe	0-15	Luminous output intensity 100%
		16-150	Proportional control of the luminous output intensity 100-0%
		151-160	Luminous output intensity 0%
		161-255	Proportional control of the strobe effect 0-100% (255=max)

### 5.5.3 DMX functions with DMX MODE = 6 channels

Channel	Function	Value	Description
1	Red	0-255	Proportional control 0-100% of the Red color
2	Green	0-255	Proportional control 0-100% of the Green color
3	Blue	0-255	Proportional control 0-100% of the Blue color
4	White	0-255	Proportional control 0-100% of the White color
5	Dimmer	0-5	Luminous output intensity 0%
		6-250	Proportional control of the luminous output intensity 0-100%
		251-255	Luminous output intensity 100%
6	Strobe	0-15	No strobe
		6-250	Proportional control of the strobe effect 0-100%
		251-255	Strobe effect 100%



## 5.6 DMX functions Dynamic white

**Warning!**  
In absence of DMX signal the led will remain ON.

### 5.6.1 DMX functions with DMX MODE = 2 channels

Channel	Function	Value	Description
1	Dynamic white	0-3	Warm white 100% - Cold white 0%
		4-122	Warm white 100% - Cold white from 0% to 100%
		123-132	Warm white 100% - Cold white 100%
		133-251	Warm white 100% to 0% - Cold white 00%
		252-255	Warm white 0% - Cold white 100%%
2	Dimmer Strobe	0-15	Luminous output intensity 100%
		16-150	Proportional control of the luminous output intensity 100-0%
		151-160	Luminous output intensity 0%
		161-255	Proportional control of the strobe effect 0-100% (255=max)

### 5.6.2 DMX functions with DMX MODE = 3 channels

Channel	Function	Value	Description
1	Warm white	0-255	Proportional control 0-100% of the warm white
2	Cold white	0-255	Proportional control 0-100% of the cold white
3	Dimmer Strobe	0-15	Luminous output intensity 100%
		16-150	Proportional control of the luminous output intensity 100-0%
		151-160	Luminous output intensity 0%
		161-255	Proportional control of the strobe effect 0-100% (255=max)

## 5.7 DMX functions monochromatic

**Attention!**  
In absence of DMX signal the led will remain ON.

Channel	Function	Value	Description
1	Dimmer Strobe	0-15	Luminous output intensity 100%
		16-150	Proportional control of the luminous output intensity 100-0%
		151-160	Luminous output intensity 0%
		161-255	Proportional control of the strobe effect 0-100% (255=max)

## 6.0 Master-Slave and Automatic function

**Ruby MC recessed** can operate without DMX signal (in AUTOMATIC mode) and can be set so that a single MASTER unit will command a series of SLAVE units. This function is particularly useful when more units are desired to execute the same programme in synchrony.

The following picture shows an example of a Master-Slave layout.

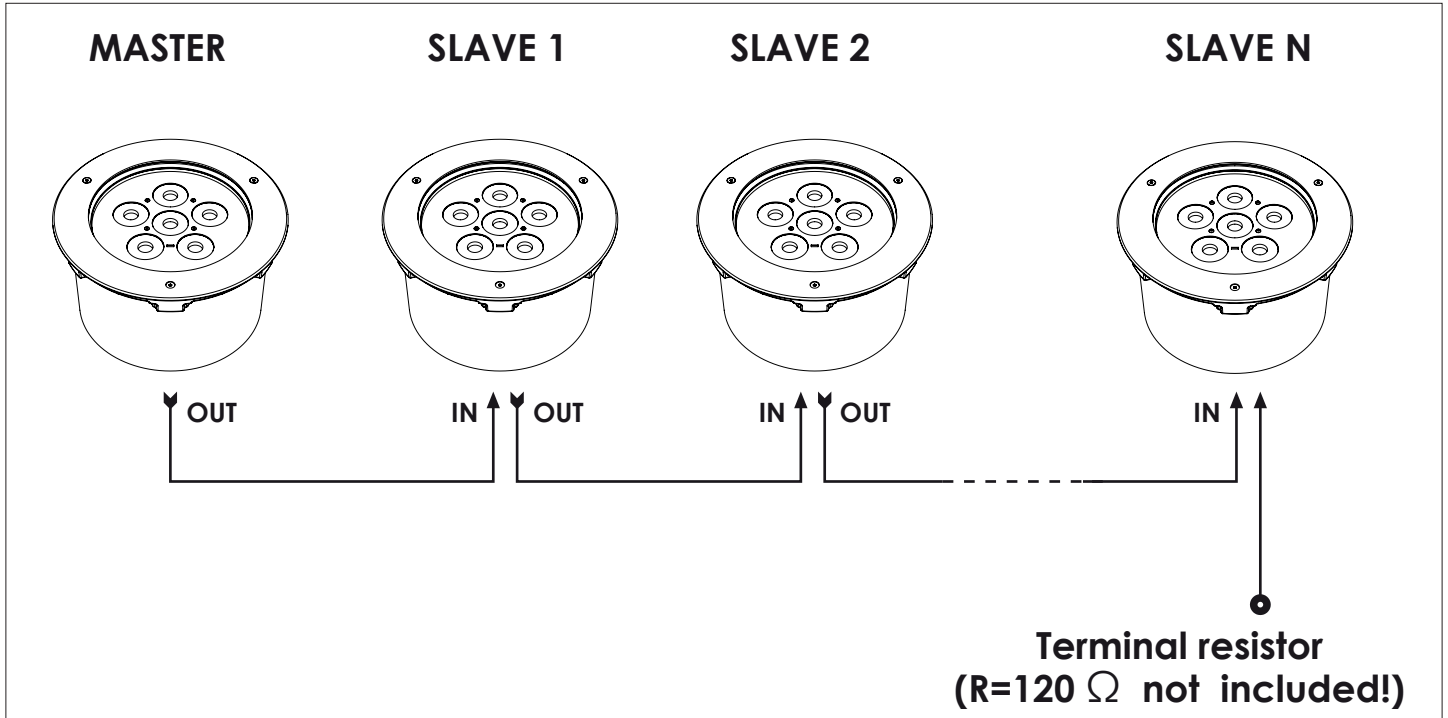

### 6.1 MASTER configuration

The projector can perform a pre-set colour-changer programme. In order to perform such pre-set programme please refer to the chart below:

Funzione	Tasti	Descrizione
Master Configuration	<b>AV</b>	the input or the removing of the automatic mode can be performed only after the log in. The programme is: green-cyan-blue-magenta-red-yellow-white. The pre-set time of each scene is 5 seconds. If the projector is turned off when it is set in automatic mode, it will switch on again in automatic mode with the same selected scene time.
Increase of the scene duration	<b>P+</b>	Available only if the projector is set in automatic mode. Increase of the scene time: 5 – 10 – 20 – 40 seconds.
Decrease of the scene duration	<b>P-</b>	Available only if the projector is set in automatic mode. Decrease of the scene time: 40 – 20 – 10 – 5 seconds.

The projector will perform a flash if you select a time of 5 seconds, 2 flashes for 10 seconds, 3 flashes for 20 seconds and 4 flashes for 40 seconds.

#### **Warning!**

**If MASTER-SLAVE mode is being used, no other DMX control device must be present along the line!!**



## 6.2 SLAVE configuration

To set up the unit as SLAVE set the unit with dmx address 001.



## 7.0 Fixed colours mode

In the FIXED COLOURS mode, it is possible to manually turn on the LEDs, without the use of a DMX. In this mode, the projector also behaves as a master and can control a number of projectors SLAVE.

### 7.1 Fixed colours mode RGBW

Function	Keys	Description
Fixed colours mode input		The preset colours mode is activated or deactivated by the (TV) key.
Colour selection	<b>1 / 2 / 3 / 4</b>	Select the colour whose intensity is intended to be adjusted by the keys from 1 to 4 (1=red; 2=green; 3=blue; 4=white).
Colour intensity	 	The intensity of the selected colour, with a 10% increase or decrease, is adjusted by the VOL+ and VOL- keys.

### 7.2 Fixed colour mode Dynamic white

Function	Keys	Description
Fixed colours mode input		The preset colours mode is activated or deactivated by the (TV) key.
Colour selection	<b>4 / 5</b>	Select the colour whose intensity is intended to be adjusted by the keys 4 or 5 (4=cold white; 5=warm white).
Colour intensity	 	The intensity of the selected colour, with a 10% increase or decrease, is adjusted by the VOL+ and VOL- keys.

### 7.3 SLAVE configuration RGBW

To set up the unit as SLAVE set the 5 channels DMX mode with address 001.

### 7.4 SLAVE configuration Dynamic white

To set up the unit as SLAVE set the 3 channels DMX mode with address 001.

## 8.0 Thermal protection

An internal temperature sensor prevents the unit from overheating. The temperature sensor will limit the current to leds, protecting their integrity, if the ambient temperature exceeds the one allowed.

## 9.0 No frost glass

The POLAR Edition of the projector is fitted with a thermal glass which is particularly useful for outdoor applications. In fact, by warming up the glass melts ice and snow which might interfere with the projection.

When the projector is on, if required by the weather conditions, the glass is automatically warmed up.

If the projection is to be started at a definite time, take care to defrost the glass in advance so that the leds can be lit at the time required.

With very cold temperatures (below  $-20^{\circ}\text{C}$ ), we recommend you to let the projector always powered and switch on the LEDs when needed.

## 10.0 RDM functions

When operating in DMX mode, the projector can accept the following RDM commands:

- discovery  
Upon request of the RDM controller, the projector adverts its own presence (the RDM controller will display the projector between a list).
- DMX address reading and setting.
- Channels number reading and setting.
- On / Off identification  
This command is used to identify the projector you want to get access to (the identification happens by switching on at full intensity all the LEDs).
- Manufacturer  
The name of the manufacturer (Griven) is displayed.
- Model description  
The projector model is displayed.
- Software version description  
The version of the firmware in use on the projector (v.x.xx) is displayed.
- Temperature  
The LEDs operating temperature value is displayed.

## 11.0 Maintenance

### **Attention!**

**Always remove mains power prior to opening up the fixture.**

To ensure maximum functionality and light output it is recommended to follow these instructions:

### 11.1 Cleaning the unit

The unit must be cleaned regularly. Cleaning regularity will depend especially on the environment where the unit will operate: deposits of dust, smokes or other wastes will reduce the light output performances.

- Clean regularly the glass of the unit.
- Do not use solvents which could damage painted surfaces.

### 11.2 Regular checks

- Check electrical connections, especially the ground wiring and the power supply cable.
- Check that the unit is not damaged mechanically. Replace those components which have got deteriorated.

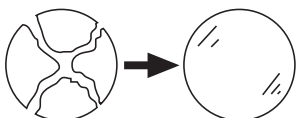

Replace damaged protection shields.

## 12.0 Spare parts

All components of the unit are available as spare parts at **Griven** dealers.

Exploded views, wiring diagrams, electronic layouts and advertising brochures are available on request.

To make the job of assistance centres easier, specify serial number and model of the unit which spare parts are requested for.

## 13.0 Troubleshooting

Inconvenience	Possible Cause	Action
The unit does not respond properly to the DMX control.	Incorrect DMX cable connection.	Check connections and wires. Rectify inefficient connections. Repair or replace damaged wires.
	Unfinished data connection.	Insert a terminal resistor in the terminal box of the last unit of the connection.
	Incorrect address assignment to the units.	Check the addresses of the units and the protocol settings.
	One of the unit is faulty and it is affecting the data transmission along the connection.	Short-circuit units singularly, one by one, since regular working is restored.
The unit is set to Slave, but does not respond properly to the Master.	There more than a unit is set to Master.	Check that amongst the interconnected fixtures, only one has been set to Master.
	Conflict in signals.	Ensure that there is no incoming DMX signal.

## 14.0 Disposal

The European Directive 2002/96/EC on Waste Electrical and Electronic Equipment (WEEE), requires that old lighting fixtures must not be disposed of the normal unsorted municipal waste stream. Old appliances must be collected separately in order to optimise the recovery and recycling of the materials they contain and reduce the impact on human health and the environment.



The crossed out "wheeled bin" symbol on the product reminds you of your obligation, that when you dispose of the appliance it the must be separately collected.

Consumer should contact their local authority or retailer for information concerning the correct disposal of their old appliance.

## 15.0 Technical specifications

### Mechanical features

Height	153mm (6")
Width	Ø263mm (10.3")
Depth	Ø232mm (9.1")
Weight	5Kg (11Lbs)

### Thermal features

Minimum ambient temperature	-40°C (-40°F)
Maximum ambient temperature	50°C (122°F)
Maximum surface temperature	<60°C (<140°F)

### Electrical features

Voltage	100-277 Vac 50/60Hz
Nominal current	0.26A@100V / 0.21A@277V
Maximum power	57W
Thermal protection	Electronic

### Light output source

Type of light output source	6 Leds
-----------------------------	--------

### Optics

Optical system	Lenses
----------------	--------

### Control

Protocol	USITT DMX-512
Control channels RGBW	4-5-6 DMX channels
Control channel Dynamic white	2-3 DMX channels
Control channel Monochromatic	1 DMX channel

### Construction

Unit body	stainless steel/Aluminium
Treatment	Scratch resistant black paint
Weather protection rate	IP67



Via Bulgaria, 16 - 46042 CASTEL GOFFREDO (MN) - Italy  
Telefono 0376/779483 - Fax 0376/779682 - 0376/779552  
<http://www.griven.com/> e-mail [griven@griven.com](mailto:griven@griven.com)  
<http://www.griven.it/> e-mail [griven@griven.it](mailto:griven@griven.it)

User's manual rel. 1.20